



Premier Fluid Systems

TCH

END-SUCTION CENTRIFUGAL PUMPS



**CAPACITY TO 6000 GPM
HEAD TO 475 FEET**

ISO 9001:2000



EXAMPLE FOR MODEL DESIGNATION

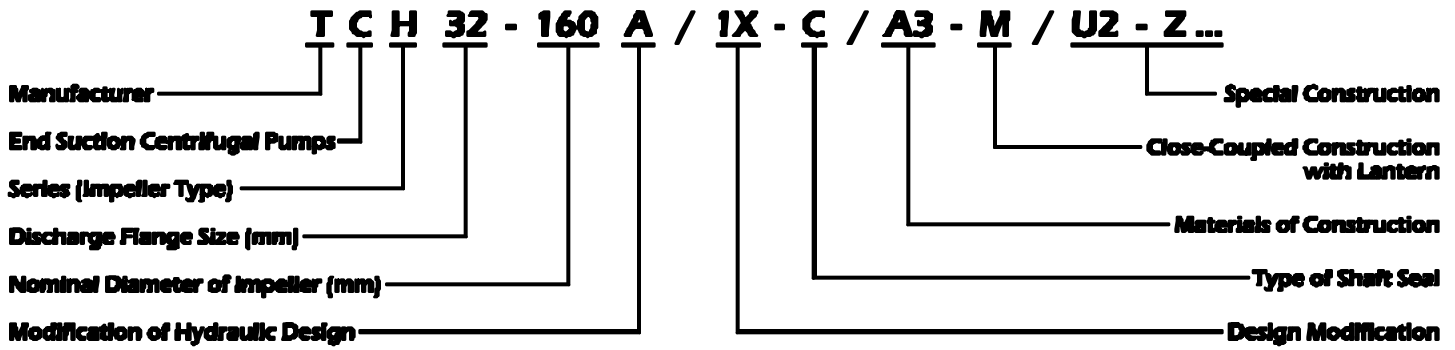

STANDARD MATERIALS OF CONSTRUCTION

Item No:	DESCRIPTION	GS	RA	A3	HC	DU	
102	Pump Casing	Ductile Iron					ASTM-CN7M
161	Casing Cover						
210	Shaft	AISI 316 Stainless Steel			Hastelloy C	Incoloy 825	
524	Shaft Sleeve						
502	Wear Rings					ASTM-CN7M	
230	Impeller						
330	Bearing Housing	Cast Iron					

SPECIAL MATERIALS AVAILABLE UPON REQUEST - For further information please consult our Sales Office.

PRESSURE AND TEMPERATURE LIMITATIONS

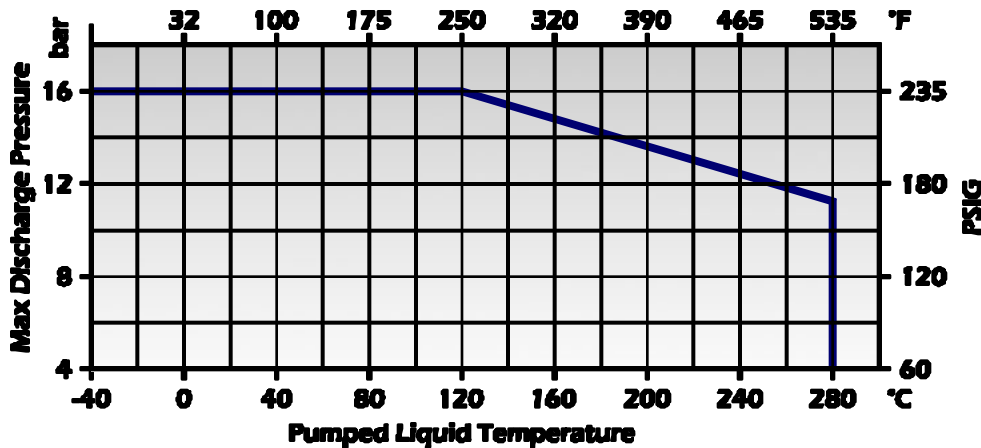

For GS and RA constructions the minimum temperature limit is -20°C. Values not valid for pumping of superheated water and similar liquids.

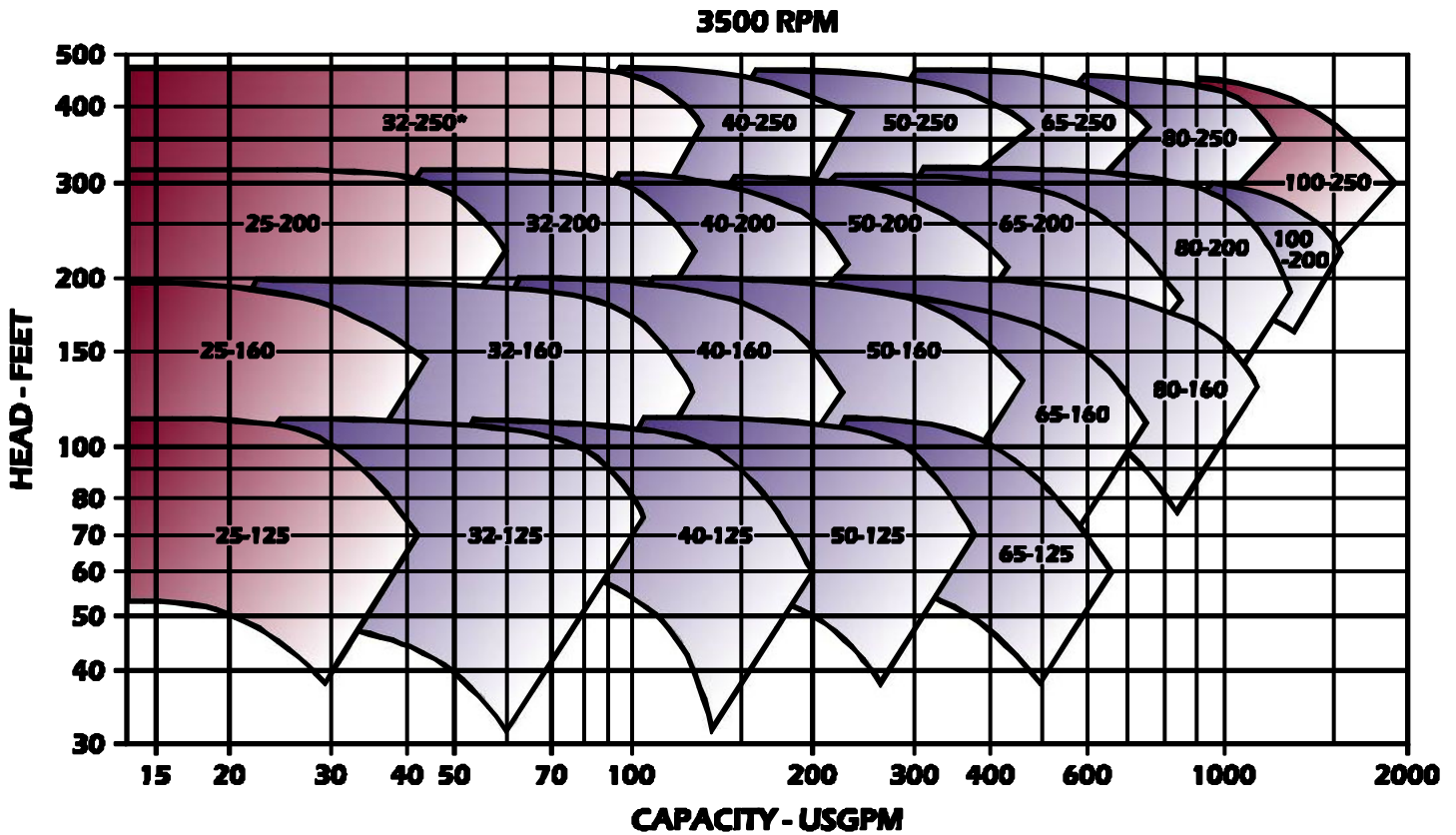
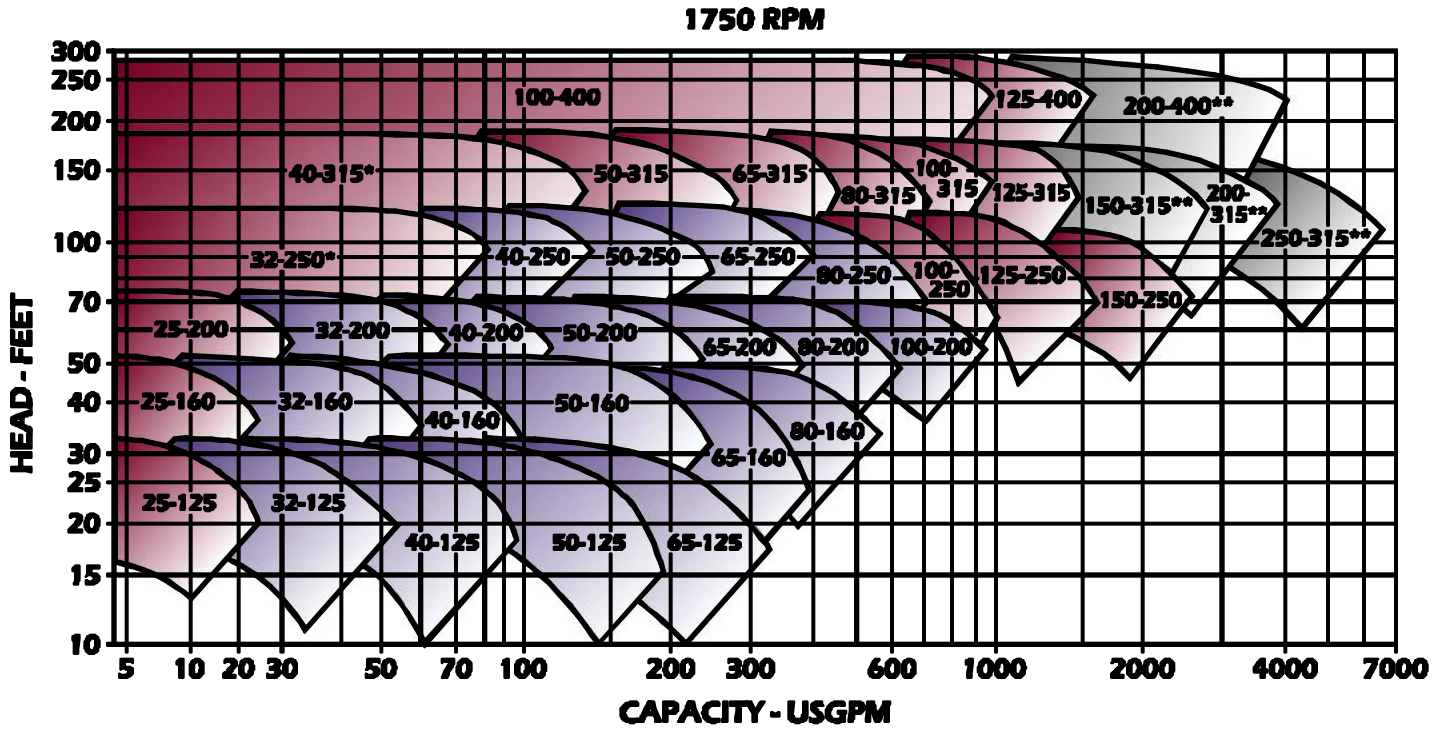

For reference only. For specific performance curves contact Premier Fluid Systems Inc.

* Presently not available

** MCU-CH gr. 4 range

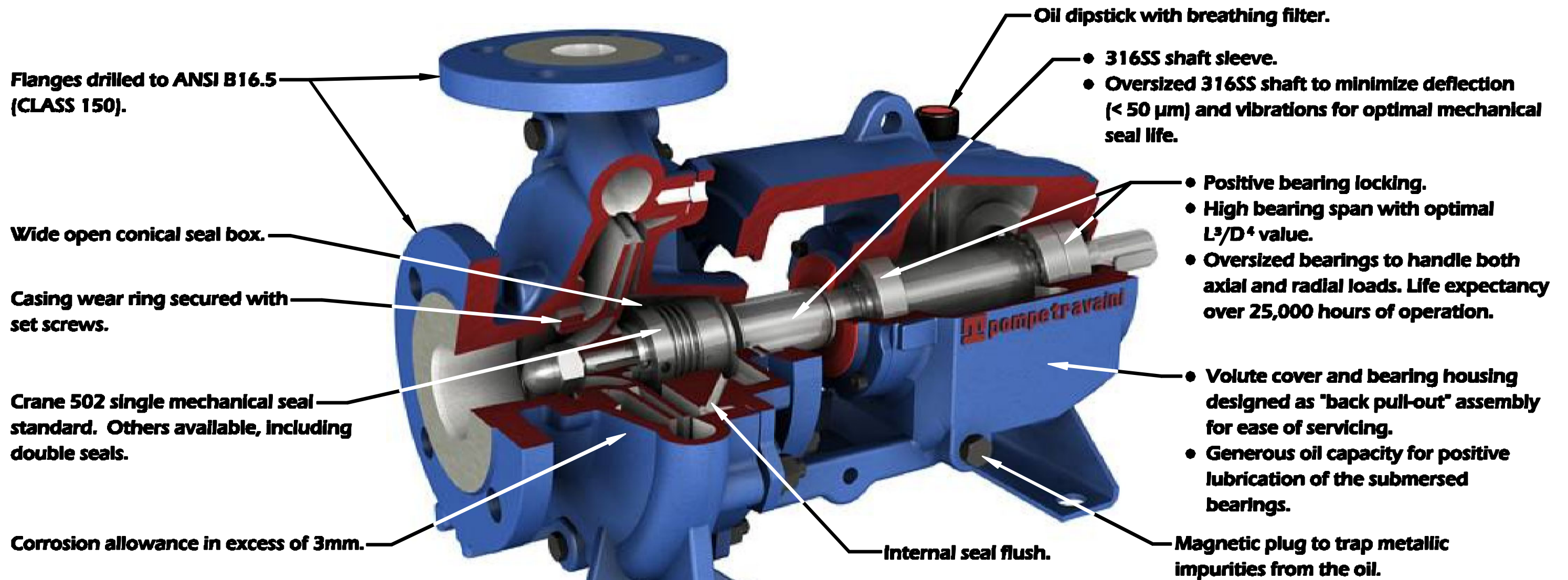

Flanges drilled to ANSI B16.5 (CLASS 150).

Wide open conical seal box.

Casing wear ring secured with set screws.

Crane 502 single mechanical seal standard. Others available, including double seals.

Corrosion allowance in excess of 3mm.

Oil dipstick with breathing filter.

- 316SS shaft sleeve.
- Oversized 316SS shaft to minimize deflection (< 50 μm) and vibrations for optimal mechanical seal life.

- Positive bearing locking.
- High bearing span with optimal L^3/D^4 value.
- Oversized bearings to handle both axial and radial loads. Life expectancy over 25,000 hours of operation.

- Volute cover and bearing housing designed as "back pull-out" assembly for ease of servicing.
- Generous oil capacity for positive lubrication of the submersed bearings.

Internal seal flush.

Magnetic plug to trap metallic impurities from the oil.

The TCH Series features a full line of single stage, end-suction centrifugal pumps, designed by **pompetravaini s.p.a.** to meet the stringent requirements of ISO 5199 for heavy duty applications, in the spirit of API 610.

TCH pumps are ideal for handling a wide range of clean to slightly contaminated liquids (including superheated, acidic, caustic) in chemical, petrochemical, pharmaceutical, food, pulp and paper, steel manufacturing, textile, and various other industries.

Known for their toughness and reliability, they offer the following:

- Capacity up to 2200 USGPM, head to 475 feet - Pump series TCH.
- Capacity up to 6000 USGPM, head to 280 feet - Pump series MCU-CH.
- High hydraulic efficiency and low NPSH requirements.
- Variety of materials available, including stainless steel, duplex stainless steel and Hastelloy C.
- Close coupled up to 40 HP (optional).
- Safety, durability, lower operating costs.

Model Type TCH/1X-C

Optional cooling water jacket design.

Cylindrical seal box allows a variety of seal options.

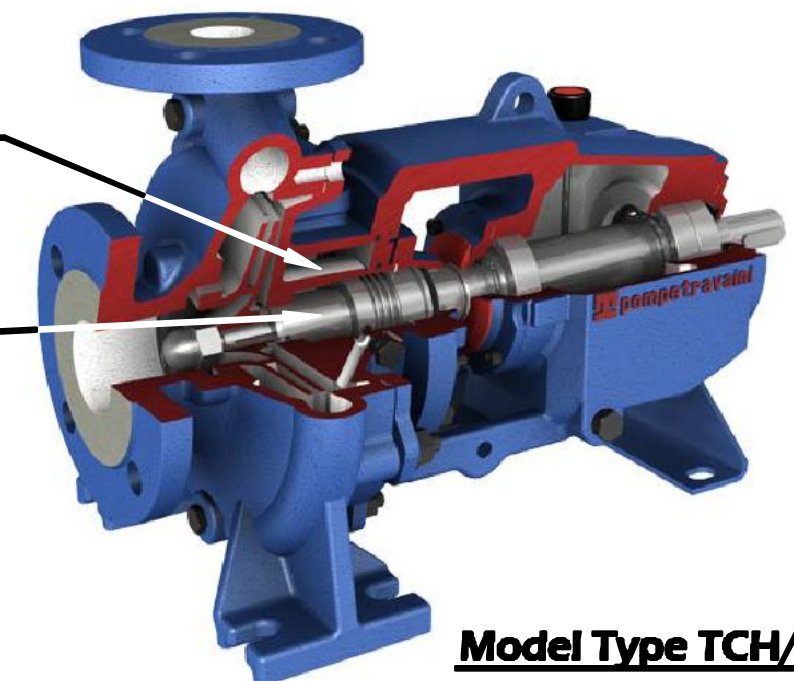

Model Type TCH/1X-R

Overall Dimensions

Series TCH

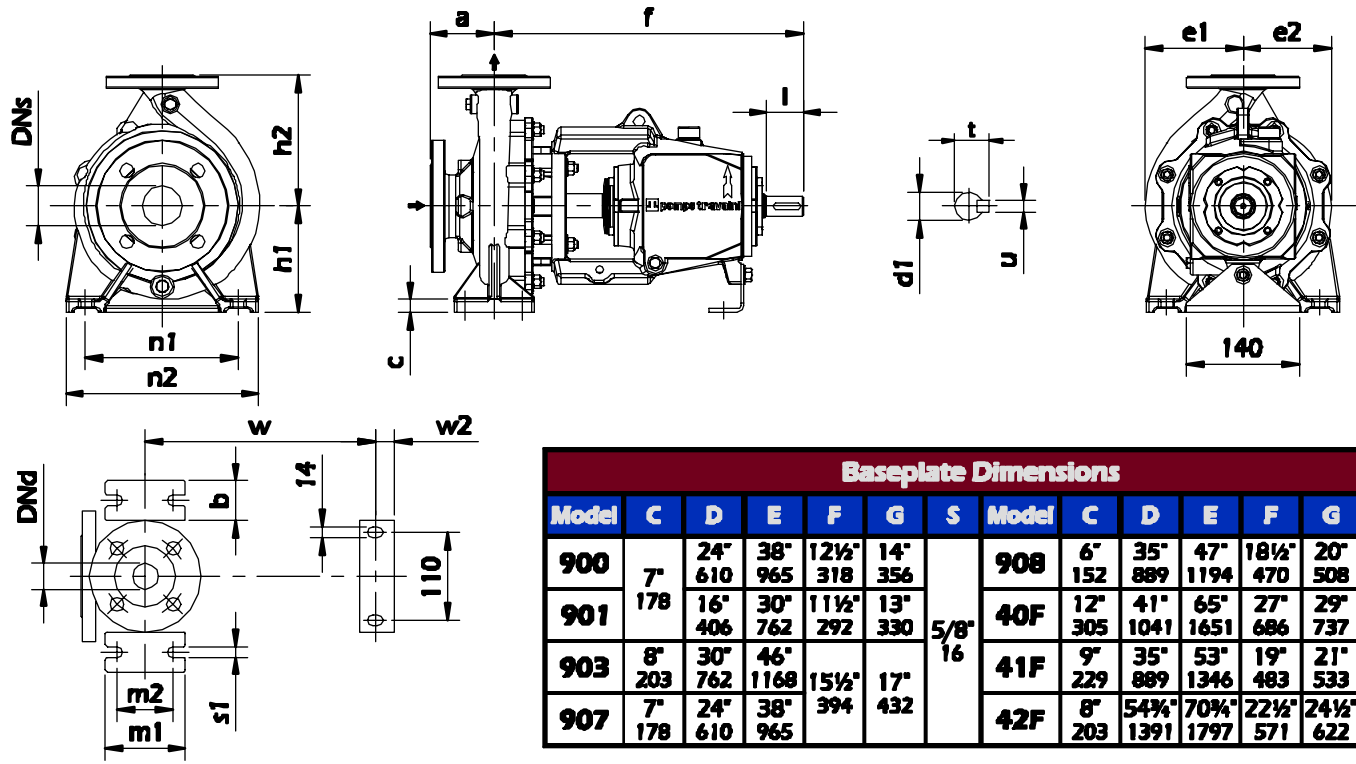

Baseplate Dimensions													
Model	C	D	E	F	G	S	Model	C	D	E	F	G	S
900	7	24" 610	38" 965	12½" 318	14" 356	5/8" 16	908	6"	35" 889	47" 1194	18½" 470	20" 508	5/8" 16
901	7/8	16" 406	30" 762	11½" 292	13" 330		40F	12"	41" 1041	65" 1651	27" 686	29" 737	
903	8"	30" 762	46" 1168	15½" 394	17" 432		41F	9"	35" 889	53" 1346	19" 483	21" 533	3/4" 19
907	7/8	24" 610	38" 965				42F	8"	54¼" 1391	70¼" 1797	22½" 571	24½" 622	

Bareshaft Construction Dimensions																							
Pump Type	DNs	DNd	a	f	h1	h2	b	c	m1	m2	n1	n2	s1	w	w2	d1	l	t	u	e1	e2	weight	
32-125	2" 50	1¼" 32	3.14 80	15.15 385	4.40 112	5.51 140	1.96 50	0.59 15	3.93 100	2.75 70	7.48 190	5.51 140	0.55 14	11.22 285	14.56 370	0.94 24	1.96 50	1.06 27	0.31 8	4.13 105	3.58 91	77 35	
32-160					5.19 132	6.29 160		0.62 16			9.44 240	7.48 190								4.92 125	4.33 110	84 38	
32-200					6.29 160	7.08 180		0.62 16			10.43 265	8.34 212								5.51 140	5.11 130	97 44	
40-125	2½" 65	1¼" 40	3.93 100	15.15 385	4.40 112	5.51 140	1.96 50	0.59 15	3.93 100	2.75 70	8.26 210	6.29 160	0.55 14	11.22 285	14.56 370	0.94 24	1.96 50	1.06 27	0.31 8	4.52 115	3.93 100	79 36	
40-160					5.19 132	6.29 160		0.62 16			9.44 240	7.48 190								5.11 130	4.52 115	88 40	
40-200					6.29 160	7.08 180		0.62 16			10.43 265	8.34 212								5.74 146	5.31 135	101 46	
40-250	3"	2" 50	3.93 100	15.15 385	19.68 500	7.08 180	8.85 225	2.55 65	0.70 18	4.92 125	3.74 95	12.59 320	9.84 250	0.55 14	11.22 285	14.56 370	1.25 32	3.14 80	1.37 35	0.39 10	6.92 176	6.41 163	181 82
50-125					5.19 132	6.29 160	0.62 16	9.44 240	7.48 190	5.11 130	4.33 110	88 40											
50-160					6.29 160	7.08 180	0.62 16	10.43 265	8.34 212	5.78 147	4.92 125	99 45											
50-200	3"	2" 50	3.93 100	15.15 385	6.29 160	7.87 200	1.96 50	0.62 16	3.93 100	2.75 70	10.43 265	8.34 212	0.55 14	11.22 285	14.56 370	0.94 24	1.96 50	1.06 27	0.31 8	6.33 161	5.74 146	104 47	
50-250					7.87 200	8.85 225		0.70 18			12.59 320	9.84 250								6.33 161	5.74 146	104 47	
65-125					4.92 125	19.68 500		7.08 180			8.85 225	0.70 18								4.92 125	3.74 95	12.59 320	9.84 250
65-160	4"	2½" 65	3.93 100	15.15 385	6.29 160	7.08 180	2.55 65	0.62 16	4.92 125	3.74 95	11.02 280	8.34 212	0.55 14	11.22 285	14.56 370	0.94 24	1.96 50	1.06 27	0.31 8	3.77 96	3.07 78	154 70	
65-200					7.08 180	8.85 225		0.70 18			12.59 320	9.84 250								6.29 160	5.11 130	161 73	
65-250					7.87 200	9.84 250		0.78 20			14.17 360	11.02 280								6.85 174	5.98 152	176 80	
80-160	5"	3" 80	4.92 125	19.68 500	7.08 180	8.85 225	2.55 65	0.62 16	4.92 125	3.74 95	12.59 320	9.84 250	0.55 14	11.22 285	14.56 370	1.25 32	3.14 80	1.37 35	0.39 10	7.32 186	5.59 142	172 78	
80-200					8.85 225	11.02 280		0.78 20			14.17 360	11.02 280								7.40 188	6.22 158	205 93	
80-250					7.87 200	9.84 250		0.78 20			14.17 360	11.02 280								8.85 225	7.28 185	238 108	
100-200	5"	4" 100	4.92 125	19.68 500	7.87 200	11.02 280	3.14 80	0.78 20	6.29 160	4.72 120	15.74 400	12.40 315	0.70 18	11.22 285	14.56 370	1.25 32	3.14 80	1.37 35	0.39 10	8.30 211	6.69 170	218 99	
					8.85 225	11.02 280		0.78 20			14.17 360	11.02 280								8.30 211	6.69 170	218 99	

Schematic drawing. Dimensions in inches and mm with tolerances to EN 735-1995 standards. Weights in lbs and kgs, referred to pump in ductile iron "GS" construction, not certified. Flanges drilled to ANSI B16.5 (CLASS 150).

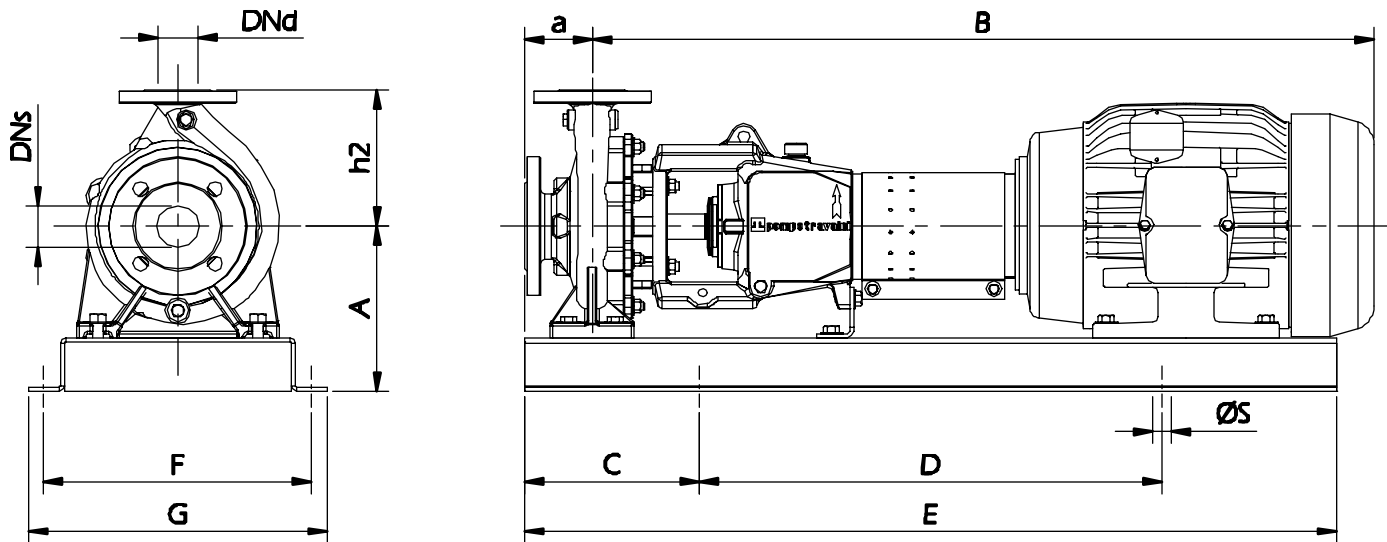

Base-Mounted Assembly Construction Dimensions

Pump Model	Motor Frame	A	B	Base	Total Weight	Motor Frame	A	B	Base	Total Weight	Motor Frame	A	B	Base	Total Weight
32-125	56	6.91"	27.53"	900	136	143T	6.91"	28.03"	900	164	145T	6.91"	29.02"	900	172
	182T	7.00"	30.77"	900	196	184T	7.00"	31.77"	900	217	182T	7.00"	30.77"	900	203
32-160	143T	7.70"	28.03"	900	171	145T	7.70"	29.02"	900	179	213T	7.75"	34.05"	900	284
	184T	7.70"	31.77"	900	224	182T	8.80"	30.77"	900	217	215T	8.80"	35.55"	900	320
32-200	145T	8.80"	29.02"	900	192	256T	9.80"	41.10"	903	505	215T	8.80"	35.55"	900	320
	254T	9.80"	39.37"	903	455	182T	8.80"	30.77"	900	217	256T	9.80"	41.10"	903	505
40-125	56	6.91"	27.53"	900	138	143T	6.91"	28.03"	900	166	182T	7.00"	30.77"	900	198
	184T	7.00"	31.77"	900	219	213T	7.75"	34.05"	900	279	213T	7.75"	34.05"	900	288
40-160	143T	7.70"	28.03"	900	175	145T	7.70"	29.02"	900	183	254T	9.75"	39.37"	903	446
	215T	7.75"	35.55"	900	311	182T	8.80"	30.77"	900	221	254T	9.80"	39.37"	903	459
40-200	145T	8.80"	29.02"	900	196	284TS	10.50"	41.22"	903	562	284TS	10.50"	41.22"	903	562
	256T	9.80"	41.10"	903	509	213T	10.59"	38.58"	903	443	286TS	10.59"	47.24"	903	697
40-250	184T	10.59"	36.42"	903	384	326TS	13.38"	50.43"	41F	994	184T	7.70"	31.77"	900	228
	324TS	13.38"	48.93"	41F	929	215T	7.75"	35.55"	900	311	254T	9.75"	39.37"	903	446
50-125	143T	7.70"	28.03"	900	175	145T	7.70"	29.02"	900	183	254T	9.80"	39.37"	903	457
	213T	7.75"	34.05"	900	288	182T	8.80"	30.77"	900	219	254T	9.80"	39.37"	903	457
50-160	145T	8.80"	29.02"	900	194	284TS	10.50"	41.22"	903	560	256T	9.80"	41.10"	903	511
	256T	9.80"	41.10"	903	507	286TS	11.00"	42.71"	907	651	324TS	12.00"	44.40"	907	801
50-200	182T	8.80"	30.77"	900	224	215T	10.59"	40.08"	903	472	324TS	13.38"	48.93"	41F	935
	284TS	10.50"	41.22"	903	564	364TS	14.38"	52.71"	42F	1266	365TS	14.38"	52.71"	42F	1366
50-250	213T	10.59"	38.58"	903	449	145T	8.80"	29.02"	900	249	184T	8.80"	31.77"	900	294
	326TS	13.38"	50.43"	41F	1000	215T	8.80"	35.55"	900	377	254T	9.80"	39.37"	903	512
65-125	143T	8.80"	28.03"	900	241	184T	9.80"	36.42"	903	364	256T	9.80"	45.63"	903	569
	213T	8.80"	34.05"	900	354	286TS	10.50"	47.24"	903	677	324TS	12.00"	48.93"	907	858
65-160	182T	9.80"	35.42"	903	344	213T	10.59"	38.58"	903	438	215T	10.59"	40.08"	903	461
	284TS	10.50"	45.75"	903	622	326TS	13.38"	50.43"	41F	989	364TS	14.38"	52.71"	41F	1174
65-200	184T	10.59"	36.42"	903	379	254T	11.87"	43.90"	907	577	364TS	14.38"	52.71"	42F	1266
	324TS	12.00"	48.93"	907	873	405TS	15.38"	56.39"	40F	1600	286TS	11.09"	47.24"	907	720
65-250	215T	11.87"	40.08"	907	504	213T	10.59"	38.58"	903	434	364TS	14.38"	52.71"	42F	1250
	365TS	14.38"	52.71"	42F	1366	326TS	13.38"	50.43"	41F	985	254T	11.09"	43.90"	907	595
80-160	184T	10.59"	36.42"	903	375	215T	10.59"	40.08"	903	490	405TS	15.38"	56.39"	40F	1617
	324TS	13.38"	48.93"	41F	920	365TS	14.38"	52.71"	42F	1383	284T	14.23"	47.24"	41F	786
80-200	213T	10.59"	38.58"	903	467	256T	14.23"	45.63"	41F	733	445TS	16.38"	61.59"	40F	2323
	364TS	14.38"	52.71"	42F	1283	444TS	16.38"	61.34"	40F	2025	215T	11.87"	40.08"	907	535
80-250	254T	12.86"	43.90"	907	628	256T	14.23"	45.63"	41F	733	256T	13.25"	45.76"	41F	713
	405TS	15.38"	56.39"	40F	1650	444TS	16.38"	61.34"	40F	2025	365TS	14.38"	52.71"	40F	1397
100-200	215T	11.87"	40.08"	907	535	254T	11.87"	43.90"	907	608	444TS	16.38"	61.34"	40F	2006
	365TS	14.38"	52.71"	40F	1397	405TS	15.38"	56.39"	40F	1631					

Above dimensions in inches and weights in lbs only for clarity.

Optional Seal Configurations

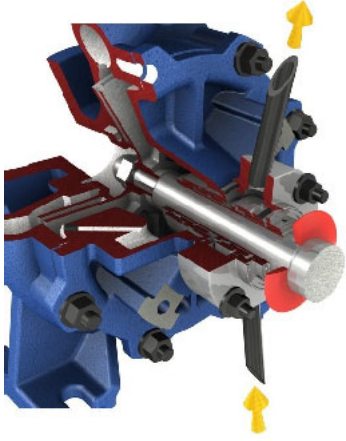

CD Construction

Mechanical cartridge seal conical chamber internal flushed.



RR Construction

Double back to back mechanical seal external flushed.

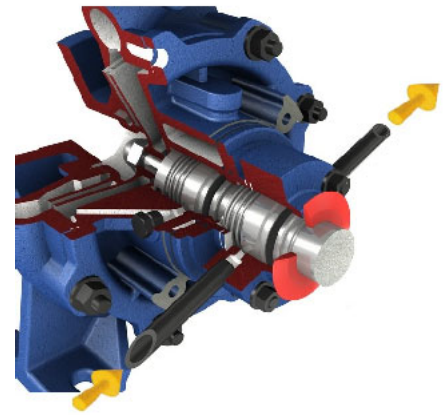

R2 Construction

Double tandem mechanical seal external flushed.

Also Available



TCD Series

- Specifically designed for handling of thermal fluids up to 320°C with no external cooling required.
- Capacity up to 1800 USGPM, head up to 470 feet.

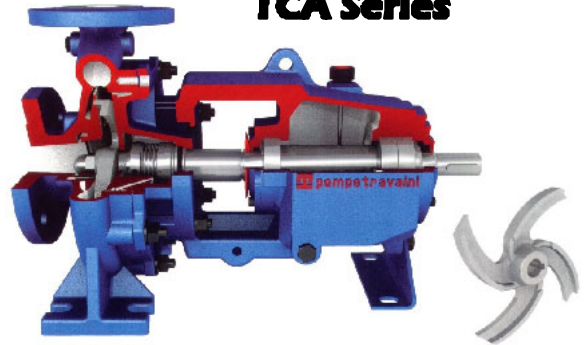

TCA Series

- Designed to handle highly abrasive liquids with suspended solids.
- Features open impeller design, high efficiency and low NPSH requirements.
- Capacity up to 500 USGPM, head up to 470 feet.

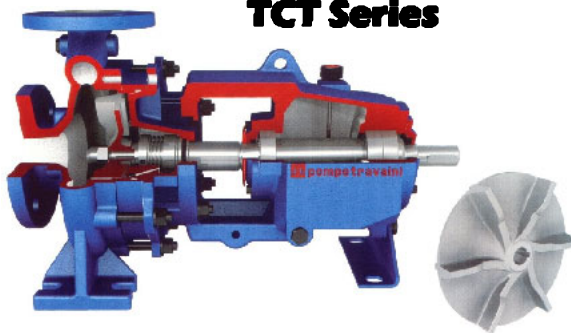

TCT Series

- Designed to handle liquids with suspended solids and viscous liquids.
- Features open vortex type impeller.
- Capacity up to 1100 USGPM, head up to 300 feet.

Distributed by:



Premier Fluid Systems
Canadian Home of Travaini Pumps

4460 Harvester Road • Burlington • Ontario • L7L 4X2 • Website: www.pfspumps.com

Tel: 1-800-461-2611 or 905-637-2611 • Fax: 905-333-4722 • e-mail: info@pfspumps.com